



## Lead American University of Beirut Inventor

**Randa Al Barazi, MD**, Assistant Professor, Pediatric Otolaryngology Head and Neck Surgery

## Background and Unmet Need

Aerodigestive foreign bodies are a significant health risk, accounting for nearly 3,000 deaths annually.<sup>1</sup> Approximately 75% of ingestions occur in children, where 20% of children between the ages of 1 and 3 swallow a non-food item at least once.<sup>2</sup> The most common items swallowed / aspirated include coins and toys, specifically marbles.<sup>3</sup> The removal of these foreign bodies requires precision tools and precise techniques. Rounded, flat, and smooth surface objects are particularly difficult to

remove, and commercially available optical forceps have been shown to cause slippage of the object, which may become further lodged within the airway. If caught within the lungs, this creates a life-threatening scenario requiring highly invasive and expensive methods of removing the foreign object, including open chest surgery.

Standard optical forceps are inadequate to remove round and smooth surface objects. Currently, basket devices used to extract these foreign bodies require at least two people, require more expertise and training to operate, are less sturdy, and are more expensive to use in a clinical setting. As a result, there is a need for less expensive Optical forceps to increase the success rate of removing aspirated foreign bodies in a controlled manner.

## Opportunity

Randa Al Barazi, MD, and her team have developed a novel optical forceps designed to extract particularly challenging foreign bodies from the airway. This device has been designed to be compatible with commercially available bronchoscopes and scopes and Dr. Barazi believes it requires less expertise to operate the device compared to alternate and commercially available basket devices.

These forceps utilize a parallelogram mechanism connected to each jaw, enabling the parallel closed position of the forceps' jaws. Each jaw includes two sets of teeth to better secure the foreign body, particularly those rounded with smooth surfaces, during extraction. The inventor believes the risk is reduced to almost zero with increased efficacy of the procedure as the physician can retrieve the foreign body in one attempt, decreasing morbidity from several attempts and decreasing the length of procedure and anesthesia time. Overall, this mechanism and design allow total grasp of foreign bodies with significantly less risk of slipping complications.

The inventor believes this device will provide significant cost savings by reducing the number of expensive and highly invasive procedures resulting from the slipping of foreign bodies by commercially

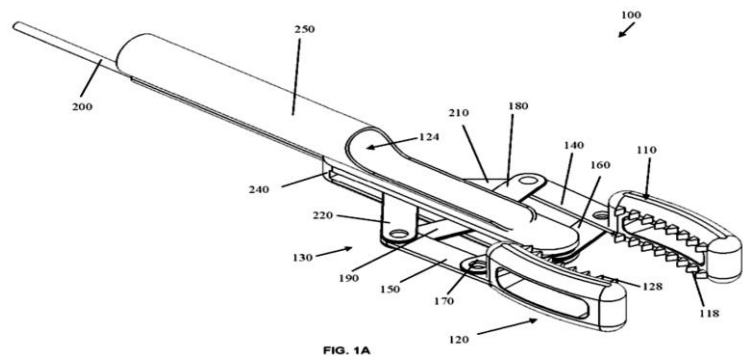

<sup>1</sup> *Foreign Bodies of the Airway*. Medscape, August 2023.

<sup>2</sup> *Young children are swallowing objects twice as often as before*. Harvard Health Publishing, May 2019.

<sup>3</sup> *Ibid*.

available optical forceps. Further, the device may be operated with a single healthcare provider, reduce the total cost of care compared to procedures that use basket devices. As a result, this device is claimed to provide an easier, cheaper, and safer retrieval solution of foreign bodies within the airway and esophagus and may be able to replace current optical forceps.

There is significant commercialization potential in the bronchoscopy and endoscopy device markets. The bronchoscopy device market has been valued at \$2.5 Bn in 2022 and is expected to grow to \$3.7 Bn by 2027 at a CAGR of 7.9%.<sup>4</sup> Further, the general endoscopy equipment market was valued at \$28.9 Bn in 2022 and is expected to reach \$40.6 Bn by 2027 at a CAGR of 7%.<sup>5</sup> Demand for such a product will likely grow as population and birth rates increase.

### Unique Attributes

- Parallel closure of the forceps jaw.
- Designed as an attachment to commercially available scopes.
- Cost saving benefits: Reduced personnel and cost requirement compared to commercially available basket devices; reduced cases of invasive surgery caused by extraction complications.
- Less medical expertise is required to operate compared to commercially available basket devices.

### Clinical Applications

- Emergency removal of swallowed and aspirated foreign bodies by children and adults.
- Potential application for foreign body removal in colorectal and gynecological settings and other endoscopic applications.

### Stage of Development

Prototype in development.

### Intellectual Property

US Patent No. 11,103,267, issued August 31, 2021.

### Collaboration Opportunity

Seeking licensee for commercialization or collaboration to advance preclinical development.

### INSTITUTIONAL CONTACT

Fadia Homeidan, PhD  
Director, Office of Grants and Contracts;  
Technology Transfer Unit and  
Center for Research and Innovation  
+961-1-374374, Ext: 2974  
fh01@aub.edu.lb

### L2C PARTNERS CONTACT

Merle Gilmore, MBA  
+1 610.662.0940  
gilmore@l2cpartners.com

Alex Togliola, MS  
+1 610.937.1067  
togliola@l2cpartners.com

---

<sup>4</sup> *Bronchoscopy Market Size, Growth by Product Bronchoscopes*, Markets and Markets, September 2022.

<sup>5</sup> *Endoscopy Equipment Market by Product*, Markets and Markets, January 2023.